

# **ATTRITOR GRINDING MILLS AND NEW DEVELOPMENTS**

**Robert E. Schilling , M. Yang  
UNION PROCESS INC.  
Akron, Ohio**

**Presented**

**by**

**Robert "Bob" Schilling**

**Presented at the Western Coatings Federation  
Monthly Dinner Meetings  
April 2000**



## ATTRITOR GRINDING MILLS AND NEW DEVELOPMENTS

### I. INTRODUCTION AND PRINCIPLES

In this presentation we will discuss the principle of the Attritor and its applications. The Attritor is a grinding mill containing internally agitated media. It has been generically referred to as a “stirred ball mill.” There are quite a few types of Attritors; we can categorize them as dry grind Attritors, wet grind Attritors, regular speed Attritors, and high speed Attritors.

A useful and simple equation describing the grinding momentum is  $M \times V$  (mass x velocity), which enables us to see how the Attritor fits into the family of mills. For example, ball mills use large media, normally 1/2” or larger, and run at a low (10-50) rpm. The other mills, such as sand, bead, and horizontal, use smaller media from 0.3mm to 2mm, but run at a very high rpm (roughly 800-1200). High speed dispersers with no media run even faster rpm (1200-1800). Various types of Attritors fall in between these. (See chart, Comparison of Grinding Mills, below).

#### COMPARISON OF GRINDING MILLS

TYPE OF MILL	MEDIA SIZE	RPM	TIP SPEED (fpm)
Ball Mill	1/2” and larger	10-50	
Attritor	1/8” to 3/8”	75-450	600-1000
Sand Mill/Horizontal mill	1/64” to 1/8”	800-1200	2000-3000
HSA Attritor	1mm - 3mm	400-1800	2600-2700
HQ Attritor	0.4mm - 3mm	1000-1900	3000
High speed disperser	-----	1200-1800	5000-6000

The most important concept in the Attritor is that the power input is used directly for agitating the media to achieve grinding and is not used for rotating or vibrating a large, heavy tank in addition to the media.

For efficient fine grinding, both impact action and shearing force must be present, Fig. 1. When wet grinding in the Attritor, impact action is created by the constant impinging of the grinding media due to its irregular movement. Shearing action is present in the Attritor as the balls (media) in their random movement are spinning in different rotation and, therefore, exerting shearing forces on the adjacent slurry. As a result, both liquid shearing force and media impact force are present. Such combined shearing and impact results in size

#### KINEMATIC POROSITY

#### EXPANDED MEDIA

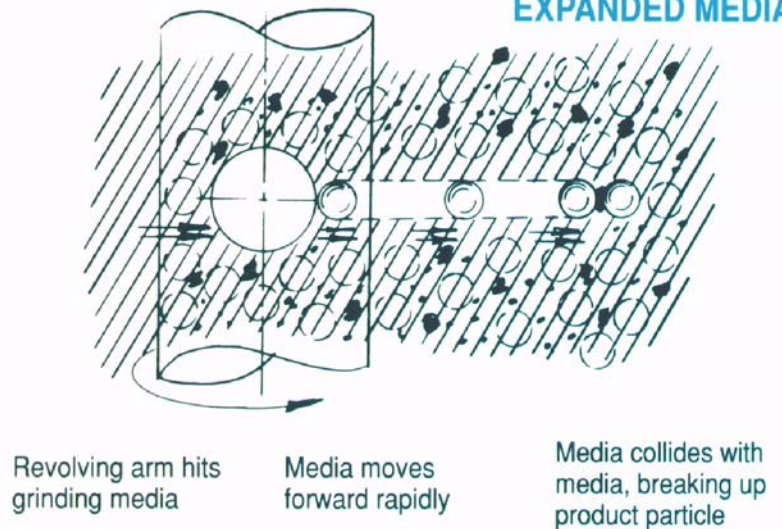

reduction as well as good dispersion.

The principle of Attritor dry grind processing is achieved by an expanded moving bed of media. This condition is described as kinematic porosity. The dry particles are subjected to various forces such as impact, rotational, tumbling, and shear; therefore, micron range fine powders can be easily achieved. Additionally, combinations of these forces creates a more spherical particle than other impact-type milling equipment.

The Attritor's versatility is gained by the ability to operate under a broad range of conditions. For example, grinding media type, size, and amount; different machine speeds; variable loading or feed rate of raw material. In addition to reducing particle size, Attritors also can create the highest intensity intimate blending of dissimilar materials. Specific chemicals or additives can also be introduced to the mill during the grinding process to achieve the ultimate dispersing or coating on the dry solid particles.

## II. GENERAL FEATURES AND OPTIONS

- Various types of Attritors can be used in wet or dry grinding process.
- A series of metal-contamination-free machines are specially designed for the ceramic industry. Several types of ceramic and polymer materials have been developed to line or sleeve the machine's internal parts. These materials include alumina, zirconia, silicon carbide, silicon nitride, tungsten carbide, rubber, polyurethane, and various plastics.
- Laboratory size Attritors are designed with variable speed drive for different RPM selections. Grinding tank sizes from 100ml to 9.5 liter.
- Production size Attritors are equipped with a specially designed 450% high torque motor for easy startup. The motor has two speeds - high speed for actual grinding, and low speed (1/3 of the high speed) for charging, discharging and cleaning procedure. The machine capacity ranges from 35 liter to 3800 liter.
- All grinding tanks are jacketed for cooling or heating.
- A torque meter can be equipped to measure the energy input, and by using the total power consumption, one can monitor the grinding process.
- Cover seals can be provided for processing under inert atmosphere.

## III. THREE BASIC TYPES OF WET GRIND ATTRITORS

Fig.2

### BATCH ATTRITORS ("S" MACHINES)

The operation of the batch Attritor (Fig. 2) is very simple. All the material can be loaded directly into the grinding tank; no premixing or pre-dispersing is needed. Since the top-open grinding tank is stationary, the process can be visually observed and corrections and additional ingredients can be introduced at any time. The maximum feed material size can be up to 10mm, provided the material is friable; otherwise, any 10 mesh down material is feasible to be processed in this machine.

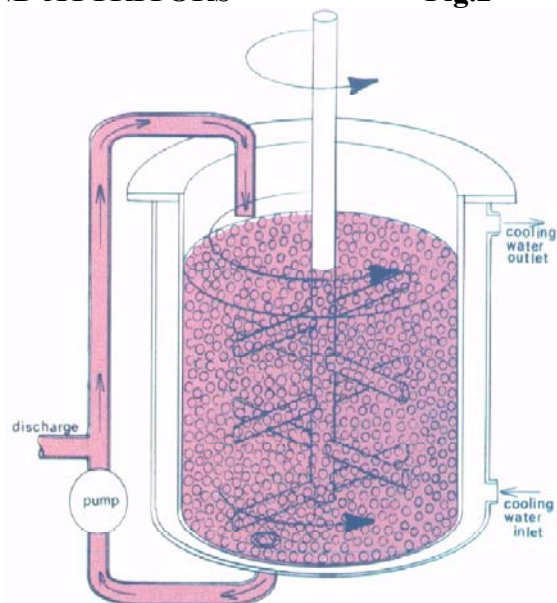

All production "S" machines are equipped with

a built-in pumping system which maintains circulation during grinding for accelerated attrition and uniformity. The pump can also be used for discharging.

Batch Attritors are used to process hard-to-grind materials, such as tungsten carbide, silicon carbide, and various metals. High viscosity slurry with up to 30,000 cps can also be processed easily in batch Attritors.

### **CIRCULATION ATTRITOR (“Q” MACHINES)** (Fig. 3)

This system is a combination of an Attritor and a holding tank which is generally 10 times the size of the Attritor. One of the essential requirements of the Q-Attritor system is the high circulation (or pumping) rate. The entire contents of the holding tank are passed through the Attritor at least once every 7-8 minutes.

At this rapid speed, the premixed slurry is pumped through a confined media bed. The media act as a dynamic sieve, allowing the fines to pass through quickly, while the coarser particles follow a more tortuous path and are ground finer. (Fig. 4) The slurry can be continuously monitored, additional ingredients can be added to the premix tank at any time during the grinding, and the processing can be terminated precisely.

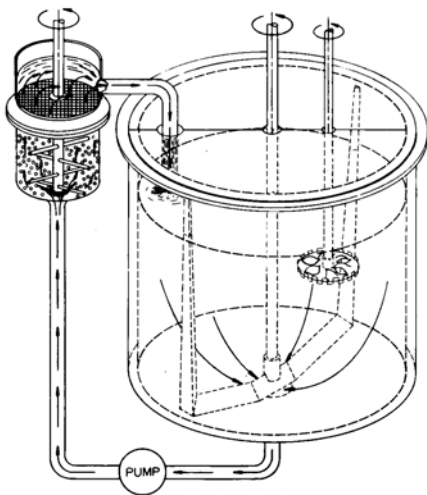

Fig. 3

*Passage Of A Small & Large Particle Through A Layer Of Agitated Media*

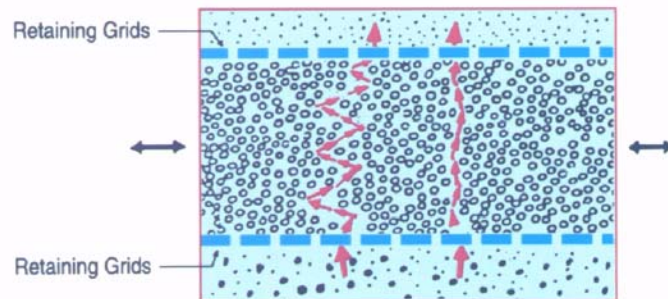

Fig. 4

One advantage of the circulation system is that large quantities of material can be handled with a smaller investment of grinding media and Attritor equipment. Another advantage of the “Q” Attritor is better temperature control, which is achievable for two reasons:

1. The holding tank is jacketed for cooling or heating and acts as a heat sink.
2. The slurry passes through the grinding chamber very quickly (20-30 seconds per pass), therefore having less time to heat up.

These advantages are very important when the grinding chamber is lined with plastic or rubber for metal-contamination-free processing.

### **CONTINUOUS ATTRITOR (“C” OR “H” MACHINES)**

(Fig.5)

C-machines are best suited for the continuous production of large quantities of material. H-machines are built the same as C-machines, but use smaller media (2-3mm) and run 60-70% higher rpm.

A well-premixed slurry is needed to be able to use this type of process. The slurry is pumped up through the bottom of the tall, narrow grinding tank and discharged out the top of the tank. The residence time required for certain fineness is controlled by the pumping rate.

The continuous Attritor can be set up in a series, using larger media and grid openings for the coarser feed, then the subsequent units with smaller media to achieve the finer grind.



#### IV. ATTRITOR GRINDING MEDIA TYPES:

Selection of grinding media depends upon several factors, some of which are interrelated.

- **Specific gravity.** In general, high density media give better results. The media should be more dense than the material to be ground. Also, highly viscous materials require media with higher density to prevent floating.
- **Initial feed size.** Smaller media cannot easily break up large particles.
- **Final particle size.** Smaller media are more efficient when ultrafine particles are desired.
- **Hardness.** The harder the media the lesser the contamination and consequently, the longer the wear.
- **pH.** Some strong acid or basic material may react with certain metallic media.
- **Discoloration.** For instance, white material should remain white.
- **Contamination.** The material resulting from the wear of the media does not affect the product or can be removed by a magnetic separator, chemically, or in a sintering process.
- **Cost.** Media that may be 2-3 times more expensive may wear better, sometimes 5-6 times longer, therefore, well worth the extra cost in the long run.

Following is a list of types of grinding media used in the Attritor:

through-hardened carbon steel	aluminum oxide
chrome steel	steatite
440C stainless steel	tungsten carbide
zirconium silicate	silicon nitride
zirconium oxide (MgO or Y <sub>2</sub> O <sub>3</sub> stabilized)	silicon carbide

#### V. NEW DEVELOPMENTS

##### “SDG” AND “HSA” DRY GRINDING ATTRITORS

##### WHY ATTRITOR DRY MILLING?

- **Process Economics:** Attritors are energy efficient, compact, easy to operate, and require low maintenance.
- **Versatility:** Attritor’s design allows modification of numerous variables to adjust changing specifications and meet the final product requirements.

- **Reduced Transportation Costs:** In many wet slurry processes, 50% of the gross weight is liquid.
- **Energy Saving:** Removal of the liquid from a wet grinding process involves not only another process step, but also requires large amounts of energy.
- **Eliminate Waste Liquid Disposal:** Following stricter environmental regulations, the disposal of any waste liquid (water or solvent) is very costly.

The SDG Attritors use grinding balls from 5mm to 13mm. The shaft RPM generally runs from 75 to 500. This series of Attritors are suitable for harder-to-grind materials such as metal powder, metal carbides, and glass chunks. The feed material size for these machines can be quite coarse, but smaller than the grinding media chosen.

The SDG Attritor is also used to make dispersion strengthened metal (DSM). In this process (known as mechanical alloying or cold welding), the kinematic porosity results in grinding media breaking the metals and additives into small particles first, then beating them together to form agglomerates. By repeating the process, the various metals are evenly mixed and dispersed to form a new composition of alloy (DSM).

Pigment industries also use SDG Attritors to dry grind some pigments for their color development.

HSA (High Speed Attritor) was newly developed in the past few years. These machines feature a unique patented design concept that includes a new grinding tank internal configuration and side discharge screen which allows mills to run at higher speed, using smaller media, and continuously discharges products out of the mill by centrifugal force. (Fig. 6)

HSA Attritors generally operate from 400-1800 RPM using grinding beads from 1-3mm. This combination of high velocity and increased grinding media surface area insure much finer grind of the processed material.

The HSA Attritor is generally used in a continuous mode. The material is charged into the mill at the top by a pre-set rate feeder, and discharged out the lower side of the grinding tank. HSA Series Attritors are generally used for finer feed material (-40 mesh), and produce large quantities of ultra fine powders in micron size. Applications include various minerals such as calcium carbonate, talc, barium sulfate, iron oxide; and rice hull ash and flyash. The HSA is also often used for fibrous and polymer types of materials.

An air classifier or screen can be incorporated with SDG or HSA Attritors to form a closed grinding process loop. By constantly taking out the fine product and reloading the oversize particles, one can achieve very efficient narrow distribution fine grinding. (Fig. 7)

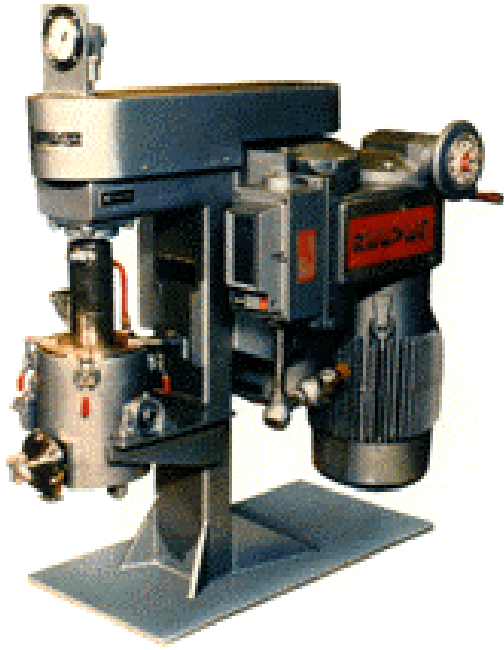

Fig. 6

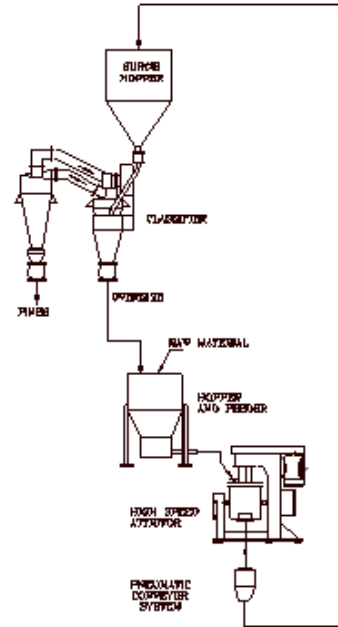

Fig. 7

**COMMON APPLICATIONS FOR DRY GRIND ATTRITORS:**

Ceramic Powders  
 Glass Frits  
 Metal Powders  
 Mechanical Alloying  
 Metal Oxides

Ferrite  
 Pigments  
 Minerals  
 Coal & Coke  
 Graphite

Fibers & Cellulose  
 Food Products  
 Plastics & Rubber  
 Chemicals

**DISCREET PASS SMALL MEDIA MILL (DELTAMILL)**

**DMQ ATTRITOR**

The DMQ is the newest member of the small media mill family. It is a hybrid of the Deltamill and the QC mills. Like the Deltamill, it utilizes Delta discs. This proprietary design eliminates shaft whip and mill vibration, while providing much greater random media motion for improved milling efficiency. The mill is designed to accommodate media from 0.3mm to 1.0mm.



As with the Deltamill, the discs are indexed to provide directed and uniform media distribution throughout the mill chamber. The mill can be used in both continuous and circulation modes. All of the mills can be produced with metal-free components for certain ceramic applications where that may be a consideration.



The mill incorporates the separator design like that used in the QC mill. It consists of a series of rings with the appropriately sized spacer between them and is thicker than the older wedge wire screen. This new design virtually eliminates plugging of the screen.

Thanks to this rugged and large open screen area positioned at the end of the mill, servicing and cleaning are much easier than with other mills. It's a simple matter to pull the cover off the end of the mill, which readily exposes the separator for servicing.



### **ADVANTAGES OF THE DMQ MILL**

1. Operates in circulation or continuous mode
2. Uses media from 1 mm to 0.3 mm
3. Delta discs eliminate shaft whip and mill vibration
4. Delta discs provide greater random media motion
5. Indexed discs provide uniform media distribution
6. Service is fast and easy
7. More durable screening mechanism
8. Milling efficiency is improved

The graph shows the increased efficiency of the DMQ mill vs. the Deltamill grinding calcined clay with a starting size of 3.6 to 3.7 $\mu$ .



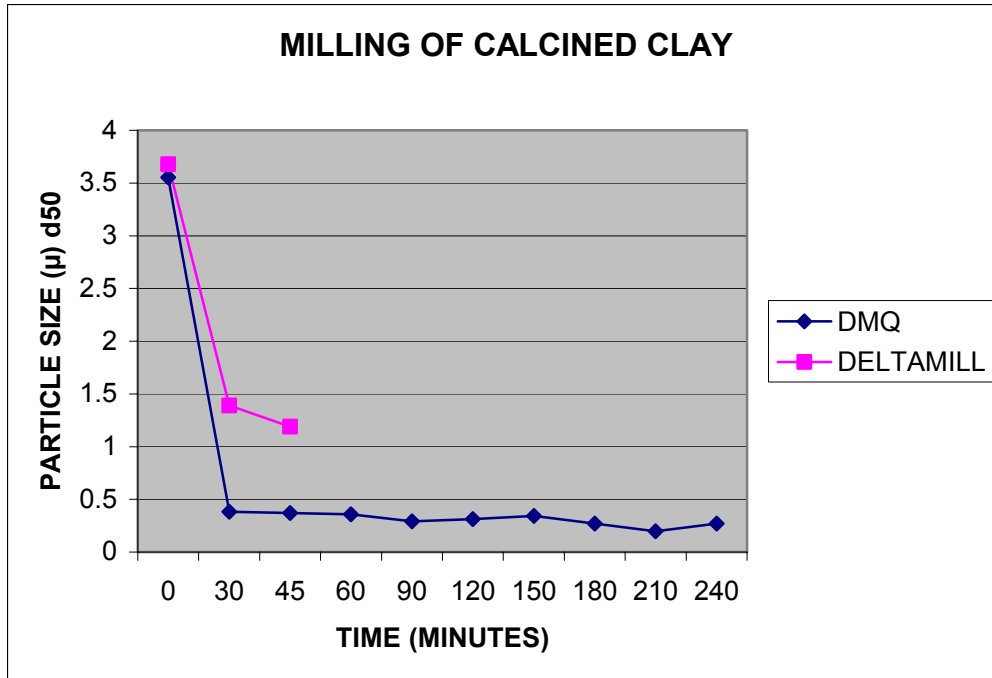

## VI. SUMMARY

### I. ADVANTAGES

1. Fast, efficient and reliable fine grinding
2. Versatility of the process
3. Low power consumption
4. Machine tank jacketed for cooling or heating temperature control
5. Easy and safe to operate
6. Low maintenance
7. Compact design, small plant area required

### II. LIMITATIONS

1. Feed material size is limited to less than 13mm for SDG Attritors.
2. For most of the sub-micron superfine powders, wet grinding still is necessary.
3. Dry grinding processes do generate more internal heat than wet grinding.

With higher and higher standards required by paint and coating industries, fine grinding/particle size reduction has become one of the most important factors for success. Over the years Attritors have proven to be an excellent and reliable means to achieve these milling tasks.

## **General Rules of Thumb of Size Reduction**

1. A specific type of machine (with fixed media, fixed operating conditions, and/or fixed equipment parameters) is most efficient in grinding a certain type of material with a certain range of feed size.
2. Size reduction over a large size reduction ration, for example  $(\text{feed size}/\text{product size}) > 10.0$ , is most efficiently accomplished by using a series of grinding stages, such as grinding machines in series, the same machine used several times in sequence, or machines combined with classification steps.
3. There is no single machine type that will grind large particles to a very fine material efficiently by repeating or prolonging the process in the same machine.
4. To avoid over grinding of material that is already smaller than some desired size, this fine material should be removed as soon as possible by classification. This process can increase grinding throughput.
5. Uniform feed size can improve grinding efficiency a great deal.
6. Production is increased and the specific energy reduced only when a grinding circuit is operated so that the size distribution is the most steep on a Schuhman plot (i.e. the most narrow size range).