

 UNION PROCESS®



**PRODUCTION  
BATCH ATTRITORS  
FOR WET GRINDING**



visit [www.unionprocess.com](http://www.unionprocess.com)

“S”

SERIES

### For Standard Batch Grinding Applications

Batch-type Production Attritors are designated as “S” (Standard). When specially configured arms are ordered as an option the model designation becomes “SL.” Batch Attritors range in size from a 10-gallon gross tank capacity to a 600-gallon gross tank capacity and from a 5 HP motor to a 150 HP motor. These versatile and easy-to-maintain grinding mills have been successfully used in a variety of industries to grind everything from chocolate to tungsten carbide. In addition, Attritors can be produced to meet the requirements of even the most stringent applications such as the electronic ceramic market. For this application, Attritors are available with metal-free systems to assure a contamination-free environment.

Batch Attritors offer the advantage that the material can be inspected any time during the grinding cycle. Therefore, adjustments or formulation additions can be accomplished without stopping the machine.

Attritors are ideal for long-term, heavy-duty, semi- and fully-automated production operations. They may also be used in conjunction with programmable controllers in highly sophisticated production environments.

### Advantages

- 10 TIMES FASTER THAN BALL MILLS
  - SIMPLE TO OPERATE
  - ENERGY EFFICIENT
  - NO PREMIXING REQUIRED
  - MINIMUM MAINTENANCE REQUIRED
  - RUGGED CONSTRUCTION
  - COMPACT DESIGN
- NO SPECIAL FOUNDATION NECESSARY

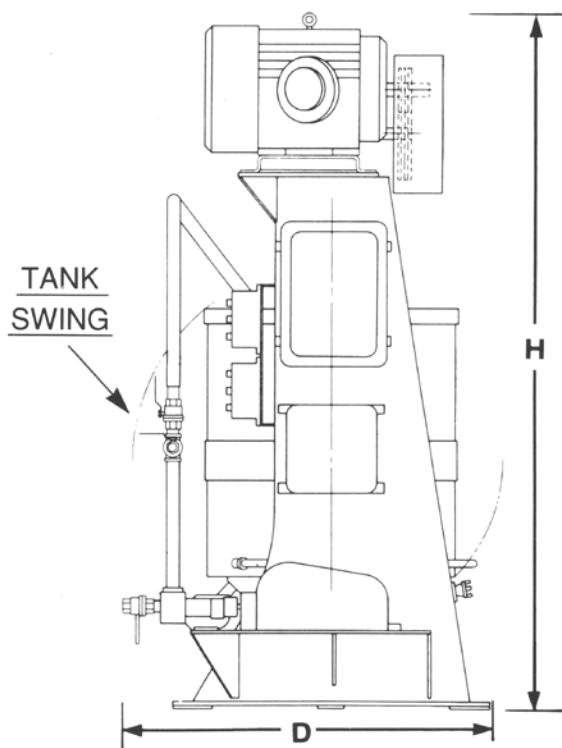
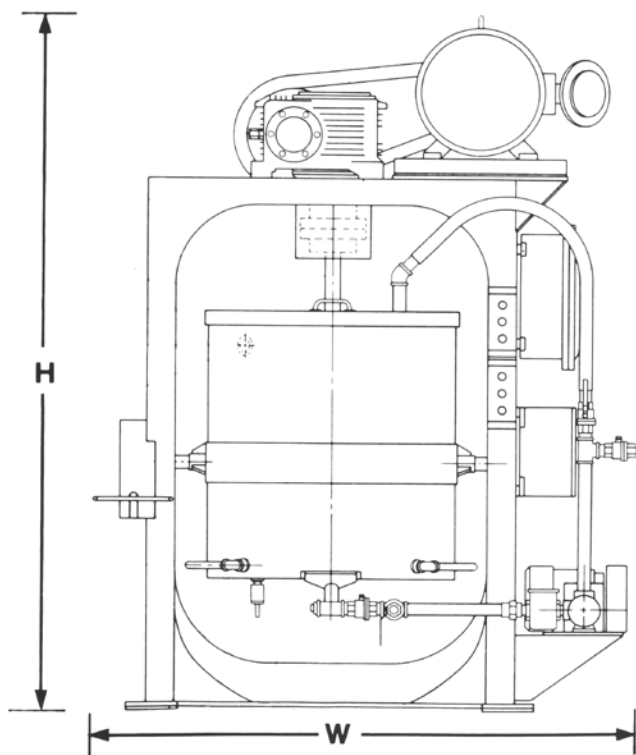

**On Cover:** Model S-100. Ceramic-lined tank with sleeved arms, plastic air diaphragm pump with plastic piping, TEFC electricals.





**SL-5**

Completely closed system for grinding under inert gas with special pre-mix tank for rare earth magnets. 5 HP, explosion-proof, mechanical variable speed drive and air diaphragm pump.



**S-10**

Air diaphragm pump, 10 HP explosion-proof variable frequency drive motor and operator station, with stop/start push buttons and speed potentiometer and meter station with digital readout of RPM and AMPS mounted on machine.



**S-30**

ASME-coded jacket design @ 50 psig. Tank has sealed cover with shaft seal. 25 HP, explosion-proof motor with remote variable frequency drive. Explosion-proof operator station with start/stop, speed potentiometer, ammeter and tachometer mounted on machine.



**SL-50**

Air diaphragm pump, machine-mounted control panel with disconnect, ammeter, TEFC electricals, CE marked.



**S-100**

Air diaphragm pump, explosion-proof electricals with ammeter.



**SL-200**

Special abrasive-resistant steel tank with lobe pump. 125 HP, explosion-proof motor with variable frequency drive and controls remotely mounted.

Some models have specially configured arms to enhance production. These units are designated with an "L" as in "30SL".

**ENGINEERING DATA**

ATTRITOR MODEL	S-5	S-10	S-15	S-30	S-50	S-100*	S-200	S-250	S-400
Gross Tank Volume (gals)	10	17	25	53	82	157	313	375	602
Slurry Capacity (gals)	4-5	7-9	10-12	23-25	34-37	70-75	140-150	177-187	280-300
Media Volume (gals)	5	9	12	25	37	75	150	187	300
HP***	3-5**	5-7.5	5-10	10-20	15-25	20-40	40-75	50-100	75-150
Height ****	79"	80"	83"	89"	98"	106"	121"	129"	147"
Floor Space (W x D)	34"x63"	52"x42"	52"x42"	61"x43"	74"x50"	82"x56"	88"x72"	90"x76"	108"x80"
Machine Weight (lbs) w/o media	1,500	1,800	2,200	3,100	3,500	6,000	10,700	12,000	16,000

\* These specifications apply to all S-100 machines since 1987 when the machine was redesigned to have a larger capacity.  
 \*\* Features variable speed drive motor. \*\*\* High Starting Torque motors. \*\*\*\* Varies according to motor HP.  
 Equipment can be built to CE specifications, if required.

# “SC” SERIES

## For Tungsten Carbide Applications

High density material such as tungsten carbide requires a specially designed heavy-duty Batch Attritor. The “SC” Series Attritor meets this special processing requirement. Available with tank capacities ranging from 7 gallons to 245 gallons and horsepowers ranging from 7.5 to 125, these powerful grinding mills feature a tapered tank to reduce load on the bottom arms for easy starting. A special lifter arm raises media and product off the bottom of the tank. Arms are sleeved with tungsten carbide to reduce wear and contamination.

The tank has a ball discharge valve and media discharge chute at the bottom for easy removal of media. A water-cooled cover with a floating teflon seal minimizes solvent loss.

The tungsten carbide Attritor is also available with a tungsten carbide tank liner or a standard stainless steel tank.

A worm gear assembly attached to the tank allows the tank to be tilted. In this position, the shaft and arms can be easily removed and/or inspected and the grinding media changed, if necessary. All models come complete with a pumping system which is used to circulate material during grinding and to discharge product.



**SC-30**

Water-cooled cover with floating shaft seal, cooling water manifold, air diaphragm pump and circulation system. Mechanical variable speed explosion-proof drive system with ammeter, tachometer, start/stop pushbuttons, and speed controls.



**SC-100**

ASME-coded cooling jacket, water-cooled cover with floating shaft seal, filter in discharge line, torque meter, actuated valves, double air diaphragm pumps, explosion-proof electricals.

## ENGINEERING DATA

ATTRITOR MODEL	S-5	S-10	S-15	S-30	S-50	S-75	S-100	S-150	S-200
Gross Tank Volume (gals)	7	12	20	42	62	87	112	161	245
Slurry Capacity (gals)	2.5-5.5	4-6	7-9	18-20	25-28	25-39	45-50	68-75	90-100
Media Volume (gals)	3	5	8	18	26	37	47	71	94
HP	7½*	10	15	20	30	40	50	75	125
Height	73"	86"	86"	92"	98"	102"	104"	118"	126"
Floor Space (W x D)	36"x64"	59"x42"	59"x42"	65"x48"	72"x54"	78"x55"	83"x56"	89"x64"	94"x72"
Machine Weight (lbs) w/o media	1,700	2,400	2,700	3,700	4,600	5,000	6,500	8,900	11,000

\* Features variable speed drive motor.

# Union Process Batch-Type Production Attritors Produce Fine, Homogeneous Dispersions Quickly and Effectively



## History

From a revolutionary idea proposed and developed by Dr. Andrew Szegvari in 1945, Attritor technology grew to become the basis for Union Process, Inc., an independent privately held American company founded in Akron, Ohio. Today, Attritors are

considered to be the most efficient grinding/dispersing systems and are used in scores of industries and research laboratories worldwide.

## How Batch Attritors Work

The Attritor is often referred to generically as an “internally agitated high energy media (ball) mill.” The operation of an Attritor is simple and effective. The material to be ground and the grinding media are placed in a stationary, jacketed tank. This media is spheres 3/32” to 3/8” diameter. Commonly used types are carbon steel, stainless steel, chrome steel, tungsten carbide, ceramic, or zirconium oxide.

The material and the media are then agitated by a shaft with arms, rotating at high speed. This causes the media to exert both shearing and impact forces on the material, resulting in optimum size reduction and dispersion.

No premixing is necessary. The material can be directly fed into the jacketed grinding tank of the Attritor. Those portions of the formulation requiring only slight grinding can be easily added later.

Attritors are equipped with VFD’s. Production batch Attritors are equipped with a built-in pumping system that maintains circulation during grinding for accelerated attrition and uniformity. This pump can also be used for material discharging. The final result of the grinding action is a fine, even particle dispersion.

Temperature control (either cooling or heating) can be maintained due to the use of jacketed tanks. When high-pressure water, coolant, oil or steam systems are required, ASME coded tank jackets may be employed. Because grinding action does not take place against the tank walls, wear of the walls is minimal. In addition, thinner walled tanks mean that improved heat transfer can be accomplished.

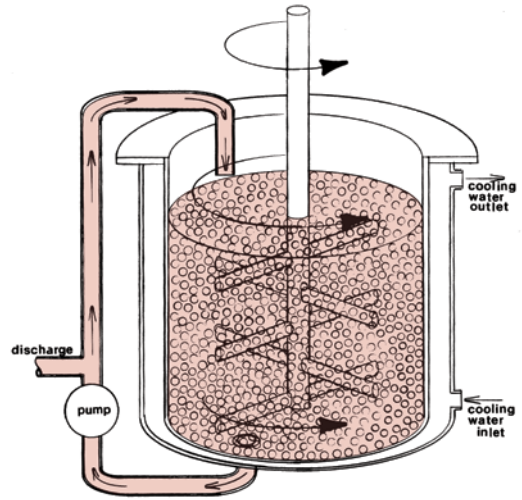

## Common Applications/Industries

- Agricultural Flowables
- Bagasse
- Biofuel/Cellulosic Biomass
- Catalysts
- Ceramics
- Chemicals
- Chocolate, Confectionery
- Cosmetics
- Cryogenic Grinding
- DSM (Mechanical Alloying)
- Electronic Ceramics
- Ferrites
- Fibers
- Food Products
- Glass Frits
- Industrial Coatings
- Metal Oxides
- Minerals, Coal
- Metal Powders and Flaking
- Paints, toners, inks
- Paper Coatings
- Pharmaceuticals
- Pigments
- Proppants
- Reaction Milling/ Mechanochemical Milling
- Tungsten Carbides

## Special Options

- **TANK LININGS**—special linings for metal-free grinding are available. Choose from ceramic (alumina) tiles, food grade rubber or polyurethane.
- **ARM SLEEVES**—to accommodate metal-free systems, shaft arms may be sleeved with plastic, tungsten carbide, or zirconium oxide.
- **COVERS**—can be equipped with a floating shaft seal to minimize solvent loss, or can be equipped with a MECO shaft seal for grinding under inert gases, complete with a product charging port, gas inlet and outlet.
- **DRIVES**—variable speed drives are available for conditions requiring the flexibility of multiple shaft speeds.
- **STATIONARY ARMS**—for reducing tank wear.
- **SPECIALLY CONFIGURED ARMS**—for increased agitation and improved performance.



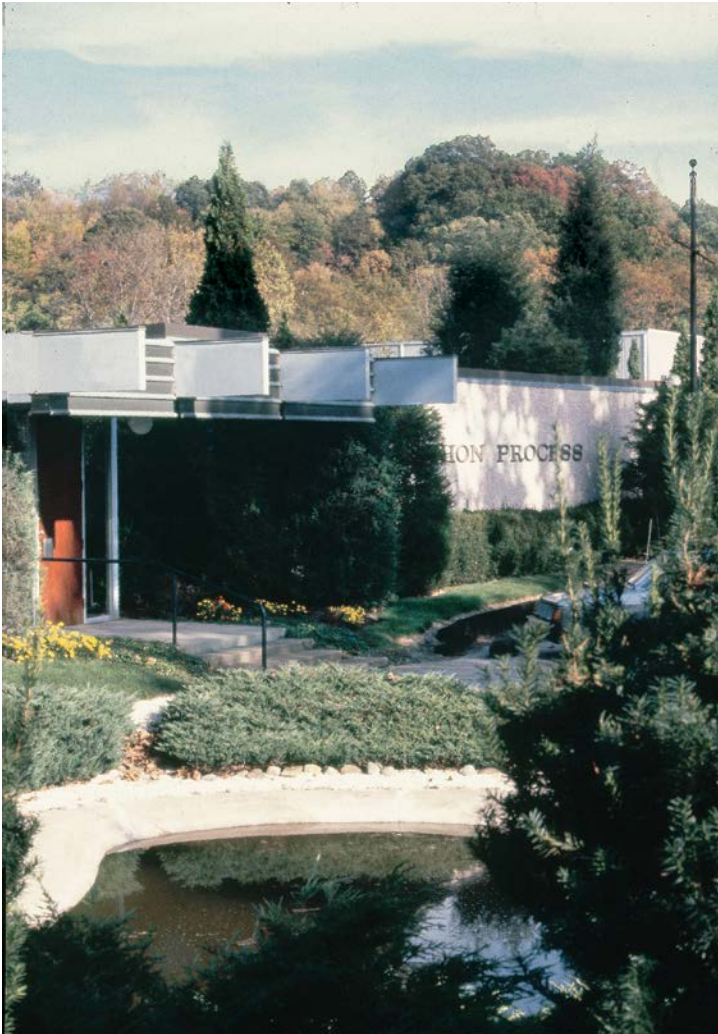

Union Process Corporate Headquarters, Akron, Ohio

## The Union Process Advantage

From years of experience in designing and building thousands of Attritors for hundreds of applications, Union Process has developed the “know-how” needed to custom design units for specific requirements, whether for production or laboratory use, employing either a dry or wet grinding process. Union Process maintains a well-equipped laboratory and pilot plant where actual production conditions can be simulated to assure that the Attritor we build for you will satisfy your requirements. Skilled technical service representatives are available for consultation. They can arrange visits to customer and prospective customer facilities to answer questions and provide solutions.

## Grinding Media

Union Process carries a full line of the highest quality grinding media to meet your particular needs.

We have selections of stainless steel, chrome steel, and thru- or case-hardened carbon steel for general use. For use with our lined, metal-free Attritors and for other specialty applications, we carry various grades of alumina, steatite, zirconium silicate, silicon nitride and silicon carbide. For the tungsten carbide industry or for applications requiring a denser media, we offer tungsten carbide.

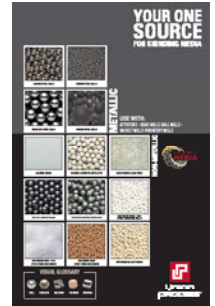

## Laboratory Attritors

For information about research and laboratory batch Attritors, request a copy of the “Laboratory Grinding Mills” brochure or download a copy from [www.unionprocess.com](http://www.unionprocess.com)

For information about wet and dry grinding systems, bead milling systems and grinding media, contact:



1925 Akron-Peninsula Road, Akron, Ohio 44313-4896

Phone: (330) 929-3333

E-mail: [info@unionprocess.com](mailto:info@unionprocess.com)

[www.unionprocess.com](http://www.unionprocess.com)

Union Process, Inc. reserves the right to make improvements or change machine and equipment designs at any time without notice. Information contained herein is accurate and reliable to the best of our knowledge, but our suggestions and recommendations cannot be guaranteed because the conditions of use are beyond our control.

“Apparatus, Process and/or Product protected under one or more of the following U.S. Patents: 4,979,686; 5,080,293; 5,199,656 and other pending patent applications as well as corresponding and related foreign patent rights.”